

Side Entry Agitator

EKATO ES2000V

The Side Entry Agitator for the Edible Oil & Fats Industry

EKATO ES2000V

Advanced Process Solutions

Function

- Optimized impeller design
- Fast & easy maintenance by advanced coupling design

Advantages

- 2 agitator sizes available
- Motor power up to 15 kW
- Single acting product lubricated mechanical seal with emergency ring
- Shut-off device
- Marine propeller or EKATO F-JET



The EKATO Service

Provides a broad range of services: "Service on site", installation, start-up, trouble shooting and availability around the clock worldwide. EKATO also provides instruction and training of the operation personal and has the required expertise for plant optimization and preventive maintenance.

EKATO

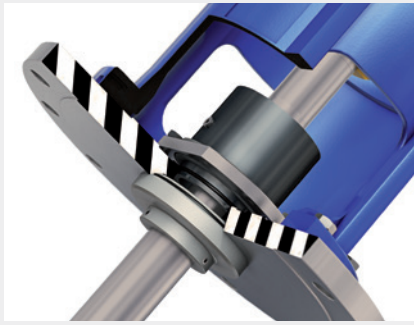

Shut-off device for mechanical seal maintenance during full tank

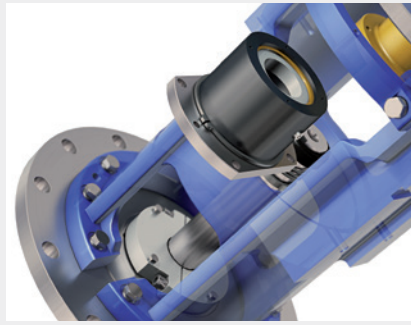

Single acting product lubricated mechanical seal easy to remove

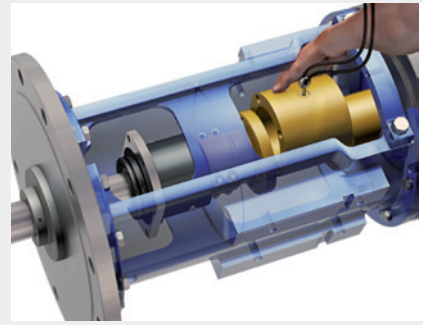

Advanced coupling design

ES2000V



Advanced coupling design

- No dismantling of the motor/gearbox for mechanical seal maintenance required
- No hoisting devices for mechanical seal maintenance required
- Fast & easy maintenance = short maintenance time

EKATO F-JET

- High efficiency design by advance product stream through blade design
- Less power consumption or shorter mixing time

