

# EKATO UNIMIX

Mixer Type:

## EKATO UNIMIX SRE

The SRE system is based on decades of experience to cope with the requirements in the pharmaceutical, cosmetic, chemical and food industry especially for bigger batch sizes.

The general features are as follows:

- According to cGMP regulations
- Vacuum / pressure tight
- Heating/cooling jacket
- PARAVISC (EKATO Patent) - agitator system with wall scrapers (other agitators are available)
- Lid fixed - bolted or welded
- The patented homogenizer EKATO UNIMIX SHV, at lowest point in vessel for external homogenization and cip cleaning. Draw in execution for powder and liquid aspiration
- Standard control system with MCC, Simatic S7, OP 170 B
- Heating / cooling system
- Vacuum producing aggregate



EKATO UNIMIX SRE 500

The standardized series of mixers type SRE has been designed and premanufactured to reduce investment costs and delivery time. SRE incorporates special features assuring safe and economical production for a wide variety of products and viscosities.

The SRE - mixers are used for the production of ointments, gels, suspensions, toothpaste, skin care as well as for specialities within the food and chemical industry.

# EKATO UNIMIX

EKATO SYSTEMS GmbH  
Käppelemattweg 2  
79650 Schopfheim  
Tel. +49 (0) 7622 29-400  
Fax +49 (0) 7622 29-600  
e-mail: unimix@ekato.com

www.ekato.com



EKATO UNIMIX SRE 100, 500, 1000

Mixer Type:

## EKATO UNIMIX SRE

| Type     | Volume (l) | Length (mm) | Width (mm) | Height, lid closed (mm) | Weight (kg) |
|----------|------------|-------------|------------|-------------------------|-------------|
| SRE 100  | 100        | 800         | 800        | 2000                    | 650         |
| SRE 250  | 250        | 950         | 950        | 2500                    | 900         |
| SRE 800  | 800        | 1250        | 1250       | 3230                    | 1930        |
| SRE 500  | 500        | 1200        | 1200       | 2800                    | 1300        |
| SRE 1000 | 1000       | 1600        | 1600       | 3350                    | 2000        |
| SRE 2000 | 2000       | 1800        | 1800       | 3800                    | 3000        |
| SRE 4000 | 4000       | 2250        | 2250       | 4500                    | 5000        |

All dimensions approximate

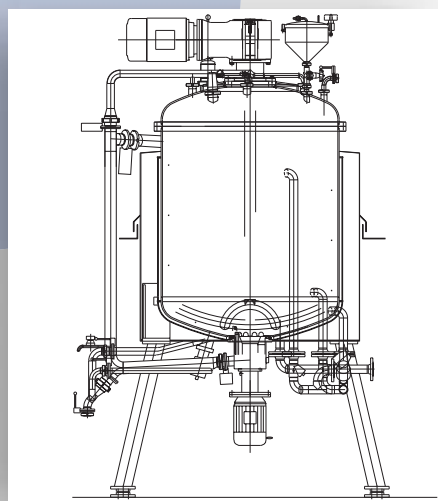

EKATO UNIMIX SRE