

# EKATO FLUID

FLUID Misch- und Dispergiertechnik GmbH  
Im Entenbad 8, 79541 Lörrach, Germany  
Tel. +49 (0) 7621 5809-0, Fax +49 (0) 7621 5809-16  
e-mail: fluid@ekato.com

[www.ekato.com](http://www.ekato.com)

FLUID MIXERS FOR WATER

## FLUID MIXERS PERFECT FOR WATER AND WASTE WATER TREATMENT

- Energy efficient mixing system with the proven impeller EKATO VISCOPROP for water and waste water treatment.
- All wetted parts in stainless steel or durable longterm coating.



Advanced Process Solutions



PHOTO BZ

# SIDE ENTRY AGITATOR ES 2000

- Energy efficient drives to optimize operation costs.
- Drive selection is based on all occurring hydraulic and mechanical forces.
- Perfected and cost-efficient technology using more than 75 years of EKATO know-how.
- Impeller diameter up to 1,300 mm
- Motor power up to 30 kW

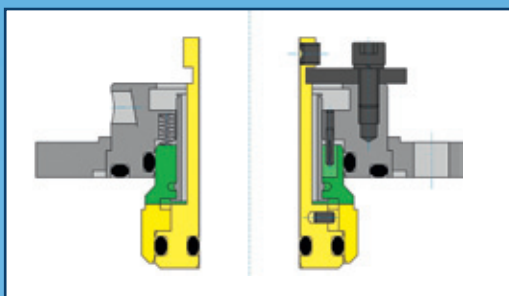
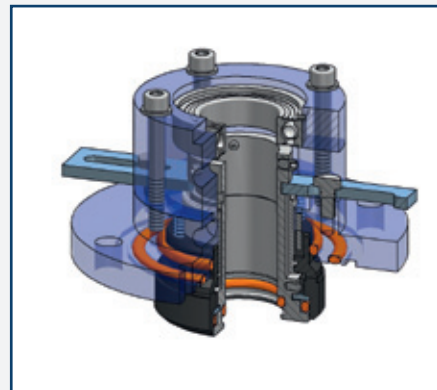

Special attention should be given to the selection of a reliable mechanical seal. FLUID applies the existing know-how of the EKATO GROUP by using mechanical seals of EKATO ESD.

Single acting product lubricated mechanical seals, or optionally double acting mechanical seals with barrier liquid can be used. Both seal types are of cartridge design.

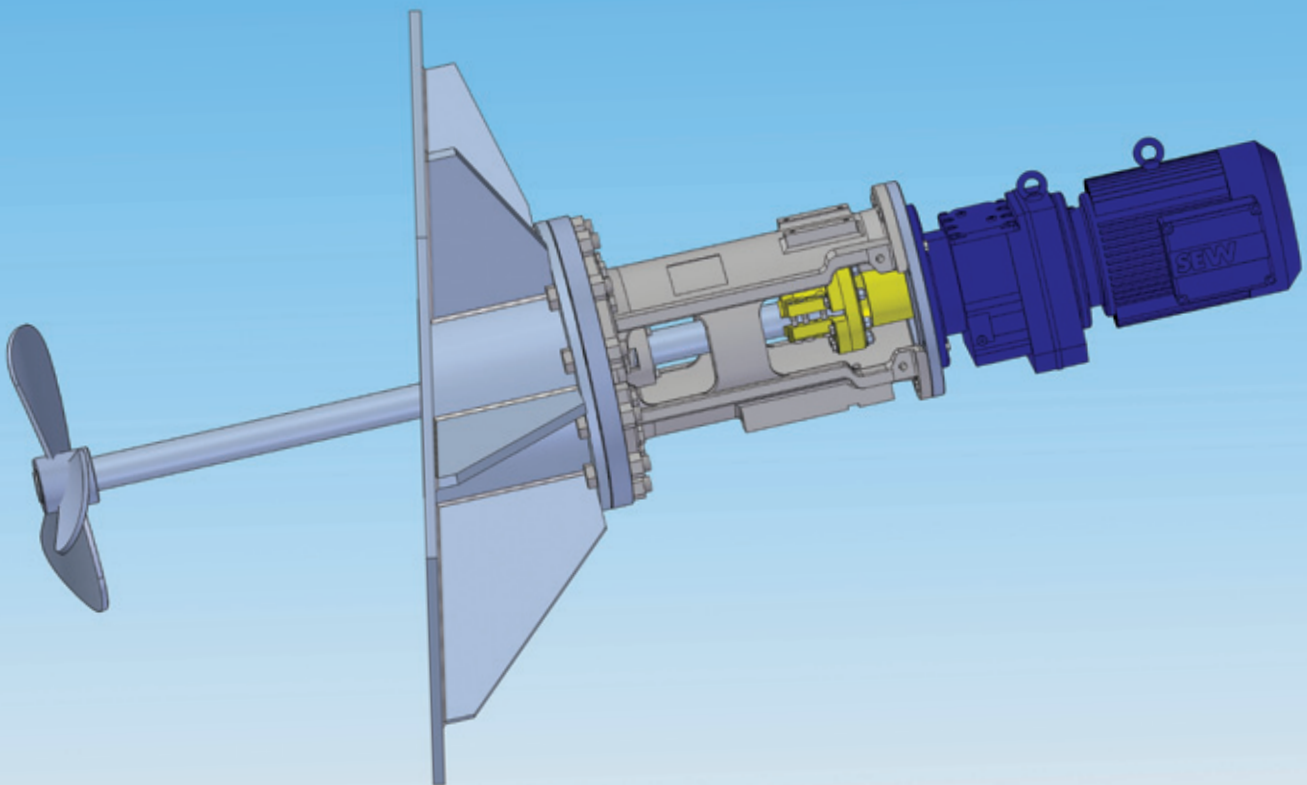

## THE EKATO SERVICE

provides a broad range of services: „Service on site“, installation, start-up, trouble shooting and availability around the clock including instruction and training of the operation personel. EKATO also has the required expertise for plant optimization and preventive maintenance.